

# TPC-2000 Series

**Modular Industrial Thin Client Multi-Touch Panel Computer with 21.5" Full HD/ 18.5" HD/17" SXGA/15" XGA/12" XGA LED LCD and Intel® Celeron® J3455 CPU**

**NEW**



## Features

- Intel® Celeron® J3455 1.50GHz Quad-core Processor with 4GB DDR3L SO-DIMM
- Modular design for flexible configuration and easy maintenance and upgrade
- Multiple sizes front panel module offering with P-Cap Multi-touch sensor (12.1" w/ robust 5-wire resistive touch)
- Industrial grade LED LCD with 50K Lifetime
- Built-in Intelligent Home-key and i-Key for Intuitive UI in models with P-Cap touch
- Front LED Indicator for system status
- Default supports Full-size mini PCIe, iDoor technology and HDD bay
- IP66 compliant Front Protection & Panel Mounting
- Ready-to-use built-in Wi-Fi antenna and NFC reader in front panel (optional Wi-Fi/ NFC module)
- Integrated Power Isolation to Minimize Field Interference
- AC/DC support (optional power adapter)
- Supports Advantech WISE-PaaS/RMM Remote Device Management Software
- Optional 3 levels of logo customization

## Introduction

TPC-2000 series is the first modular model in industrial thin client family. With industrial grade LCD and low power consumption embedded Intel® Celeron® J3455 1.50GHz processor and 4GB DDR3L SO-DIMM, it provides sufficient display area and ideal computing performance in a compact fanless system. Modular design further gives users the flexibility to expand and configure the system and is effortless to maintain and upgrade. Front panel IP66 compliant for wide array of user environments, glass surface with 6H or above harness for P-Cap or robust 5-wire resistive touch and die-cast Aluminate Alloy front bezel provides robust and reliable enclosure of the system. User-friendly Wi-Fi and NFC antenna are integrated in the front panel with optimal reception and sensitivity for optional Wi-Fi & NFC module. In addition, through the Mini-PCIe slot, Advantech iDoor technology (optional) can provide more I/O connectors, Isolated Digital I/O, the Fieldbus Protocol, 3G/GPS/GPRS Communication and MRAM to fulfill various demands of diverse applications in industrial automation.

## System Specifications

### General

- BIOS** AMI UEFI
- Certification** BSMI, CCC, CE, FCC Class A, UL, EAC
- Cooling System** Fanless design
- Enclosure** Front bezel: Die-cast Aluminum alloy  
Back housing: SECC
- Mounting** Panel Mount, optional stand mount kit and optional VESA mount kit
- OS Support** Microsoft® Windows 10 IoT Core, Windows 10 IoT Enterprise LTSB Entry
- Power Input** 24 V<sub>DC</sub> ± 20%
- Watchdog Timer** 1 ~ 255 sec (system)

### System Hardware

- CPU** Intel® Celeron® J3455 1.50GHz Processor
- Memory** 4GB (Optional 8GB) DDR3L 1600MHz SO-DIMM SDRAM
- LAN** 10/100/1000 Base-T x 2 LAN (2 x Intel® I210)
- Expansion Slots** Full-size Mini PCIe supports GSM 11.11 SIM Card Stand slot
- Storage** M.2 (2242) slot x 1  
2.5" SATA SSD slot x 1
- I/O** RS-232/422/485 x 2  
USB 3.0 x 2  
USB 2.0 x 2  
Audio line out x 1  
Displayport port x 1

### Environment

- Humidity** 10 ~ 95% RH @ 40°C, non-condensing
- Ingress Protection** Front panel: IP66
- Vibration Protection** With SSD: 1 Grms (5 ~ 500 Hz) (Operating, random vibration)

## System/Front Panel Selection

Category	Item	12.1"	15"	17"	18.5"	21.5"
LCD	Display Type	XGA TFT LED LCD	XGA TFT LED LCD	SXGA TFT LED LCD	HD TFT LED LCD	Full HD TFT LED LCD
	Max. Resolution	1024 x 768	1024 x 768	1280 x 1024	1366 x 768	1920 x 1080
	Max. Color	16.2 M	16.7 M	16.7 M	16.7 M	16.7 M
	Luminance (cd/m <sup>2</sup> )	600	400	350	250	300
	Viewing Angle (H/V°)	160/140	160/140	160/140	170/160	178/178
	Backlight Life	50,000	50,000	50,000	30,000	50,000
	Contrast Ratio	700:1	700:1	800:1	1000:1	5000:1
Touch	Type	5-wire Resistive	Projected Capacitive	Projected Capacitive	Projected Capacitive	Projected Capacitive
	Light Transmission	Above 75%	90% ± 3%	90% ± 3%	90% ± 3%	90% ± 3%
	Treatment	Anti-glare	90% ± 3%	90% ± 3%	90% ± 3%	90% ± 3%
System	Temperature	Operating	0 ~ 50°C (32 ~ 122°F)	0 ~ 50°C (32 ~ 122°F)	0 ~ 50°C (32 ~ 122°F)	0 ~ 50°C (32 ~ 122°F)
		Storage	-30 ~ 70°C (-22 ~ 158°F)	-30 ~ 70°C (-22 ~ 158°F)	-30 ~ 70°C (-22 ~ 158°F)	-20 ~ 60°C (-4 ~ 140°F)
	Power Consumption	46.5W	44W	51W	48W	55W
	Wi-Fi/NFC in Front Panel	N/A	Built-in antenna in front panel with optional module			
	Built-in iKey	No	Yes	Yes	Yes	Yes

## Dimensions

Unit: mm

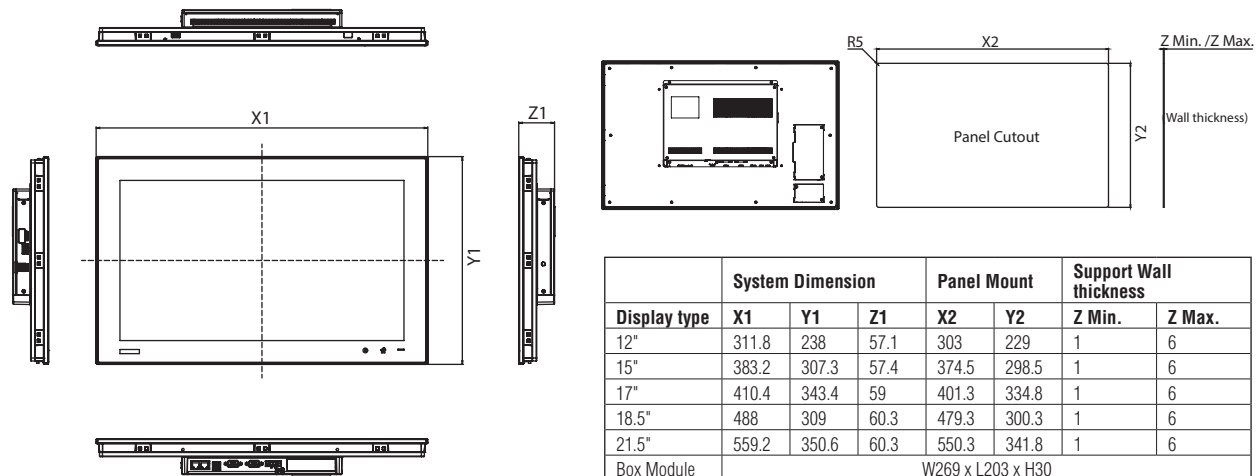

## Ordering Information

### Configurable System

<b>BOX Module P/N</b>	<b>TPC-B200-J12AE</b>
Description	Intel® Celeron® J3455 1.50GHz, DDR3L 4GB

Panel Module P/Ns	FPM-D12T-AE	FPM-D15T-AE	FPM-D17T-AE	FPM-D18W-AE	FPM-D21W-AE
Description	12.1" XGA TFT LED LCD	15" XGA TFT LED LCD	17" SXGA TFT LED LCD	18.5" HD TFT LED LCD	21.5" Full HD TFT LED LCD

### Pre-Configured System System

- TPC-2121T-J12AE** 12.1" XGA Modular TPC, Intel® Celeron® J3455 1.50GHz Quad-core Processor, 4GB RAM, Resistive touch
- TPC-2151T-J12AE** 15" XGA Modular TPC, Intel® Celeron® J3455 1.50GHz Quad-core Processor, 4GB RAM, P-Cap Touch
- TPC-2181W-J12AE** 18.5" HD Modular TPC, Intel® Celeron® J3455 1.50GHz Quad-core Processor, 4GB RAM, P-Cap Touch (Available by March 2018)

## Optional Accessories

- PWR-247-CE** 60W DC 24V/2.5A Output Power Supply
- 1702002600** Power Cable US Plug 1.8 M
- 1702002605** Power Cable EU Plug 1.8 M
- 1702031801** Power Cable UK Plug 1.8 M
- 1700000596** Power Cable China/Australia Plug 1.8 M
- TPC-5000T-WMKE** TPC series Wall Mount Kit for 12"-21"
- TPC-1000H-SMKE** TPC Stand kit from 10" to 17" TPC
- TPC-RUSB-W10LTSBE** Win10 IoT Ent LTSB 2016 MultiLang ORY Entry EPKEA
- 98R35000010** Wi-Fi module 802.11 bgn/RT5390 1T1R with USB signal
- 98R35000000** USB NFC/RFID module ADT-006

## iDoor Modules

- PCM-26D2CA-AE** SJA1000 CANBus, CANOpen, DB9 x 2
- PCM-26D1DB-MAE** Hilscher netX100 FieldBus, ProfiBus, DB9 x 1
- PCM-27D24DI-AE** Digital I/O, 16 DI / 8 DO, Isolation, DB37 x 1
- PCM-24D2R4-AE** OXPcie-952 UART, Isolated RS-422/485, DB9 x 2
- PCM-24D2R2-AE** OXPcie-952 UART, Isolated RS-232, DB9 x 2
- PCM-24R2GL-AE** 2 Port Giga LAN Intel i350 PCIe mini card
- PCM-24R1TP-AE** Intel 82574L, GbE, IEEE 1588 PTP, RJ45 x 1

\* Contact Advantech for more options.

## Rear View

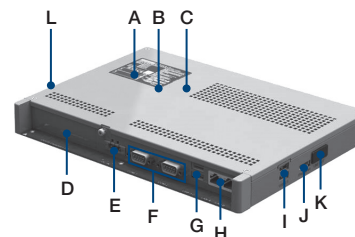

- A. Hard Disk Bay
- B. mPCIe
- C. M.2 (SATA only)
- D. iDoor
- E. Power Receptor
- F. RS-232/422/485 x 2
- G. USB 3.0 x 2
- H. LAN (10/100/1000) x 2
- I. USB 2.0 x 2
- J. Display Port
- K. Audio Line out
- L. Antenna opening

## Application Software

<b>WebAccess/SCADA</b>	Advantech WebAccess is a 100% web based SCADA (Supervisory Control And Data Acquisition) software and it acts as an IIoT Platform providing open interfaces for partners to develop IoT applications for different vertical markets. In addition to traditional SCADA functions, WebAccess has an intelligent Dashboard, to provide users with cross-platform, cross-browser data analysis and user interface using HTML5 technology. As well as the built-in widgets, WebAccess also provides Widget Builder to allow customers to build their own.
<b>WebAccess/HMI</b>	WebAccess/HMI is Human Machine Interface (HMI) software based on Microsoft's Windows operating system. It utilizes a PC's ample resources, ie speed, storage, multimedia, peripheral devices, and large screen to produce a complex human-machine interface. WebAccess/HM with its communication and monitoring ability supports more than 350 PLC communication protocols and a wide choice of screen design objects, to satisfy multiple integrations of factory automation and all-round human-machine interface operation and monitoring requirements.