

Features

- 8 opto-isolated digital input channels
- 8 relay actuator output channels
- 2 opto-isolated PWM outputs
- LED indicators to show activated relays
- Jumper selectable dry contact/wet contact input signals
- Up event counters for DI
- Programmable digital filter function for DI
- Pattern Match interrupt function for DI
- Change of State interrupt function for DI

Introduction

The PCI-1760 relay actuator and isolated D/I card is a PC add-on card for the PCI bus. It provides 8 opto-isolated digital inputs with isolation protection of 2500 VDC for collecting digital inputs in noisy environments, 8 relay actuators for serving as ON/OFF control devices or small power switches, and 2 isolated PWM (Pulse Width Modulation) outputs for user's specific applications.

For easy monitoring, each relay is equipped with one red LED to show its ON/OFF status. Each isolated input supports both dry contact and wet contact so that it can easily interface with other devices when no voltage is present in the external circuit.

Digital Filter Eliminates Unexpected Input Noise

To eliminate unexpected signals or noise from the card circuitry, each digital input channel has a programmable digital filter. When the digital filter is enabled, the state of the corresponding input channel will not update until one high/low signal has lasted for a period which is set by the user.

Interrupt Function Ensures Faster System Response

The PCI-1760 provides a irPattern Matchle interruption function for the digital input channels. The PCI-1760 monitors the state of some or all of the input channels and then compares them with a pre-set pattern. The PCI-1760 generates an interrupt signal to the system when the inputs match the pattern.

The "Change of State" interrupt function monitors the state of the input channels. When any input changes its state, the PCI-1760 interrupts the system to handle this event.

These interrupt functions release the CPU from the burden of polling all the I/O points, enabling a PC to handle more I/O points with higher performance.

Up event counter for Each DI

Each isolated digital input channel is connected to a 16-bit UP event counter. A counter will increment by 1 whenever it reads either a rising-edge (low to high) or a falling-edge (high to low) input signal with the maximum frequency of 500 Hz. When the counter overflows or reaches a pre-set value (chosen by software), it generates an interrupt signal to the PC.

Applications

- Digital signal and contact status monitoring
- Industrial On/Off control
- Signal switching
- External relay driving

Specifications

Isolated Digital Input

- **Channels:** 8
- **Opto-isolator:** PC354
- **Input voltage:** 5 ~ 12 V
High: > 4.5 V
Low: < 1.0 V
Uncertain: $1.0\text{ V} \leq V_{in} \leq 4.5\text{ V}$
- **Input resistance:** 1K W 1/4 W
- **Isolation voltage:** 2500 V_{DC}
- **Digital Filter:**
Minimum effective High input period $\geq [(2 \sim 65535) \times 5\text{ ms}] + 5\text{ ms}$
Minimum effective Low input period $\geq [(2 \sim 65535) \times 5\text{ ms}] + 5\text{ ms}$

Relay Actuator and Isolated D/I Card

- **16-bit UP counter:**
Maximum effective input frequency: 500 Hz
Minimum High period ≥ 1 ms
Minimum Low period ≥ 1 ms

Relay Output

- **Channels:** 8
- **Relay type:** single-pole double-throw (SPDT, Form C)
- **Output type:**
CH0 and CH1: NC and NO outputs
CH2 ~ CH7: NC or NO outputs (selected by jumper)
- **Rating contact load:** 120 V_{AC} @ 0.5 A or 30 V_{DC} @ 1 A
- **Contact resistance:** less than 100 m Ω initially
- **Dielectric strength:**
Coil to contacts (deenergized): 1500 V_{RMS} (1 minute)
Between open contacts (deenergized & energized): 1000 V_{RMS} (1 minute)
- **Life expectancy:**
200,000 operations @ 0.5 A 120 V_{AC}
500,000 operations @ 1.0 A 30 V_{DC}
- **Operating & Releasing time:**
Operating time: 5 ms max.
Releasing time: 5 ms max.

Isolated PWM output

- **Channel:** 2
- **Isolation voltage:** 2500 V_{DC}
- **Scaling resolution:** 16 bits (100 ms for each step)
High period = [(1 ~ 65535) x 100 ms] + 50 ms (max.)
Low period = [(1 ~ 65535) x 100 ms] + 50 ms (max.)
- **Output level:** High: (5 \pm 0.5) V
Low: < 0.8 V

General

- **Power consumption:** +5 V @ 450 mA (typical), 850 mA (max.)
- **Operating temperature:** 0° ~ +60° C (32° ~ 140° F) (refer to IEC 68-2-1, 2)
- **Storage temperature:** -20° ~ +70° C (-4° ~ 158° F)
- **Operating humidity:** 5% ~ 95% RH non-condensing (refer to IEC 68-2-3)

Physical

- **Connector:** One 37-pin D-type connector
- **Dimensions:** 175 mm (L) x 100 mm (H) (6.9" x 3.9")

Block Diagram

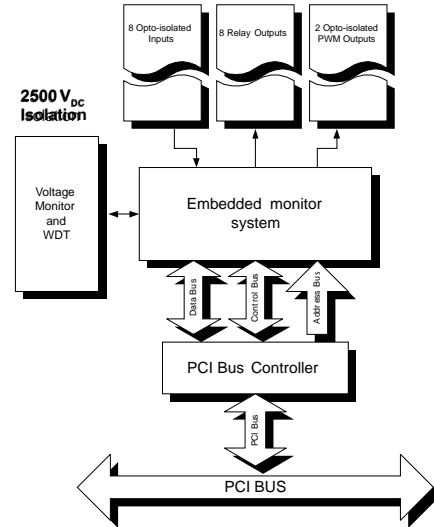

Pin Assignments

IGND	1	20	ID17+
ID17-	2	21	ID16+
ID16-	3	22	ID15+
ID15-	4	23	ID14+
ID14-	5	24	ID13+
ID13-	6	25	ID12+
ID12-	7	26	ID11+
ID11-	8	27	ID10+
ID10-	9	28	PWM2
PWM1	10	29	R5_OUT
R8_OUT	11	30	R4_OUT
R7_OUT	12	31	R3_OUT
R6_OUT	13	32	R2_NO
R8_COM	14	33	R2_NC
R7_COM	15	34	R2_COM
R6_COM	16	35	R1_NO
R5_COM	17	36	R1_NC
R4_COM	18	37	R1_COM
R3_COM	19		

Ordering Information

- **PCI-1760:** Relay Actuator and Isolated D/I Card, user's manual and driver CD-ROM (cable not included)
- **PCL-10137-1/2/3:** DB-37 cable assembly, 1, 2 and 3 m
- **ADAM-3937:** DB-37 wiring terminal for DIN-rail mounting