



InTemp CX450 Temp/RH Logger

Included Items:

- Two AAA 1.5 V alkaline batteries
- Battery door and screw
- NIST Certificate of Calibration

Required Items:

- InTemp app
- Device with iOS and Bluetooth

The InTemp CX450 logger measures temperature and relative humidity (RH) for storage and transportation monitoring in the pharmaceutical, life science, and medical industries. This Bluetooth® Low Energy-enabled logger is designed for wireless communication with a mobile device. Using the InTemp app, you can easily configure the logger, download reports, and monitor tripped alarms. Or, you can use InTempConnect® to configure and download the logger via the CX5000 Gateway. Use the built-in LCD screen on the logger to view the current temperature and humidity, logging status and battery usage, and also to check and clear maximum and minimum readings. Once data is uploaded to InTempConnect, you can track logger configurations and automatically upload logger data to build custom reports for further analysis.

Specifications

Temperature Sensor

Range	-30° to 70°C (-22° to 158°F)
Accuracy	±0.5°C from -30° to 70°C (±0.9°F from -22° to 158°F)
Resolution	0.024°C at 25°C (0.04°F at 77°F)
Drift	<0.1°C (0.18°F) per year

RH Sensor

Range	0 to 95% (non-condensing)
Accuracy	±3% from 0% to 90% and ±3.5% from greater than 90% typical at 25°C (77°F)
Resolution	0.01%
Drift	<1% per year typical

Logger

Radio Power	1 mW (0 dBm)
Transmission Range	Approximately 30.5 m (100 ft) line-of-sight
Wireless Data Standard	Bluetooth Low Energy (Bluetooth Smart)
Logger Operating Range	-30° to 70°C (-22° to 158°F), 0 to 95% RH (non-condensing)
NIST Calibration	Two-point NIST calibration included
Logging Rate	1 second to 18 hours
Time Accuracy	±1 minute per month at 25°C (77°F)
Battery Type	Two AAA 1.5 V alkaline or lithium batteries, user replaceable
Battery Life	1 year, typical with logging interval of 1 minute. Faster logging intervals, remaining connected with the InTemp app, excessive report generation, numerous audible alarms, and paging all impact battery life.
Memory	178 KB (103,400 total measurements or 51,700 temp & RH paired measurements)
Full Memory Download Time	Approximately 60 seconds; may take longer the farther the device is from the logger
LCD	LCD is visible from 0° to 50°C (32° to 122°F); the LCD may react slowly or go blank in temperatures outside this range
Dimensions	9.4 x 5.6 x 2.59 cm (3.7 x 2.21 x 1.02 inches)
Weight	90.2 g (3.18 oz)
Environmental Rating	IP54



The CE Marking identifies this product as complying with all relevant directives in the European Union (EU).



See last page

Logger Components and Operation

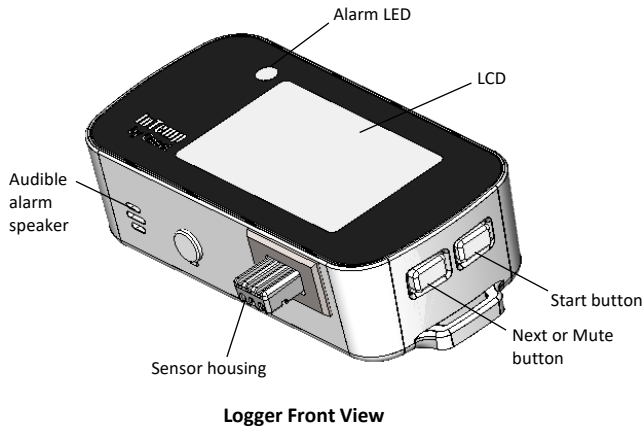

Logger Front View

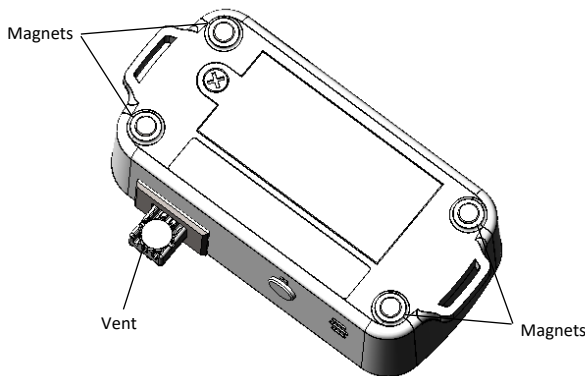

Logger Back View

Start Button: Press this button for 3 seconds to start the logger when it is configured to start “on button push.” You can also press this button for 1 second to bring the logger to the top of the list in the app. Press and hold both buttons on the logger simultaneously for 3 seconds to clear the minimum and maximum values on the LCD (see *Minimum and Maximum Values*) or for 10 seconds to reset a passkey (see *Passkey Protection*).

Next or Mute Button: Press this button for 1 second to switch between the temperature and humidity readings on the LCD. You can also press this button for 1 second to mute a beeping alarm (see *Logger Alarms*). Press and hold both buttons on the logger simultaneously for 3 seconds to clear the minimum and maximum values (see *Minimum and Maximum Values*).

Sensor Housing: Both the temperature and RH sensors are located within the housing that protrudes from the case.

Audible Alarm Speaker: This is the speaker for the audible alarm that beeps when an alarm is tripped. See *Logger Alarms*.

Alarm LED: This LED blinks every 5 seconds when an alarm is tripped. See *Logger Alarms*.

Magnets: Use the four magnets on the back for mounting the logger.

Vent: This is a membrane-covered vent for proper sensor operation. Do not remove the protective membrane.

LCD: This screen shows the latest sensor readings and other status information. The LCD screen refreshes at the same rate as the logging interval. The example shows all symbols illuminated on the LCD screen followed by a table with descriptions of each symbol.

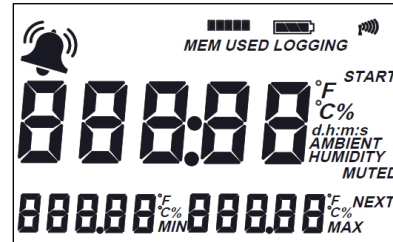

LCD Symbol	Description
	An alarm has tripped because the sensor reading is outside the specified range. See <i>Logger Alarms</i> .
	This indicates how much memory has been used for the current configuration. In this example, approximately 40 percent of the memory has been used.
	This shows the approximate battery power remaining.
LOGGING	The logger is currently logging.
	The logger is currently connected to a phone or tablet via Bluetooth. The more bars there are, the stronger the signal.
START	The logger is waiting to be started. Press and hold the Start button for 3 seconds to start the logger.
35.68 ^{°F} _{AMBIENT}	This is an example of a temperature reading.
47.29 _{% HUMIDITY}	This is an example of an RH reading.
36.58 ^{°F} _{MIN}	These are examples of minimum temperature and RH readings. Press and hold both buttons on the logger simultaneously for 3 seconds to clear the minimum and maximum values on the LCD. See <i>Minimum and Maximum Values</i> for additional details.
41.76 _{% MIN}	
40.23 ^{°F} _{MAX}	These are examples of the maximum temperature and RH readings. Press and hold both buttons on the logger simultaneously for 3 seconds to clear the minimum and maximum values on the LCD. See <i>Minimum and Maximum Values</i> for additional details.
48.95 _{% MAX}	
MUTE or MUTED	MUTE indicates an alarm is beeping. Turn off the beeping alarm by pressing the Mute button. The LCD then changes to MUTED.
CH 1-P OFF	The audible alarm has been muted.
05:38 _{ms}	The logger has been configured to start logging on a delay. The display will count down in days, hours, minutes, and seconds until logging begins. In this example, 5 minutes and 38 seconds remain until logging will begin.
LoAd	The profile settings are being loaded onto the logger from the app.
Err	An error occurred while loading the profile settings onto the logger from the app. Try reconfiguring the logger.

LCD Symbol	Description
HELLO	The logger was paged from the app.
STOP	The logger has been downloaded and stopped with the app or because the memory is full.
Hold	This is displayed while pressing the top button for 3 seconds to start the logger or when pressing both buttons for 3 seconds to clear the minimum and maximum values on the LCD.
boot	The logger is being updated with new firmware.

Note: If the logger has stopped logging because the memory is full, the LCD screen will remain on with “STOP” displayed until the logger is downloaded to your mobile device. Once the logger has been downloaded, the LCD will turn off automatically after 2 hours. The LCD will turn back on the next time the logger connects with your device.

Getting Started

InTempConnect is web-based software where you can monitor CX450 logger configurations and view downloaded data online. Using the InTemp app, you can configure the logger with your phone or tablet and then download reports, which are saved in the app and automatically uploaded to InTempConnect. The CX5000 Gateway is also available to automatically configure and download loggers and upload data to InTempConnect (see www.intempconnect.com/help for details). You also have the option to use the logger with the InTemp app only.

Follow these steps to begin using the logger:

- 1. Set up an InTempConnect account.** Follow all steps if you are a new administrator. If you already have an account and roles assigned, follow step c.

If you are using the logger with the InTemp app only, skip to step 2.

- Go to www.intempconnect.com and follow the prompts to set up an administrator account. You'll receive an email to activate the account.
 - Log into www.intempconnect.com and add roles for the users you will be adding to the account. Click Settings and then Roles. Click Add Role, enter a description, select the privileges for the role and click Save.
 - Click Settings and then Users to add users to your account. Click Add User and enter the email address and first and last name of the user. Select the roles for the user and click Save. New users will receive an email to activate their user accounts.
- 2. Set up the logger.** Insert two AAA batteries in the logger, observing polarity. Insert the battery door in the back of the logger making sure it is flush with the rest of the logger case. Use the included screw and a Phillips-head screwdriver to screw the battery door into place.
 - 3. Download the InTemp app and log in.**
 - Download InTemp to a phone or tablet from the App Store®.
 - Open the app and enable Bluetooth in the device settings if prompted.
 - InTempConnect users:** Log in with your InTempConnect user credentials. (Your device must be able to connect to

the internet.) Make sure to check the box that says “I am an InTempConnect user” when signing in.

App only users: If you will not be using InTempConnect, create a local user account and log in when prompted. DO NOT check the box that says “I am an InTempConnect user” when signing in.

4. Set up a logger profile.

InTempConnect users (requires privileges):

- In InTempConnect, select Loggers > Logger Profiles.
- Click Add Logger Profile.
- Type a profile name.
- Select CX450 for the Logger Family.
- Select a Logging Interval, Start option, and any alarms.
- Tap Save to add the new profile.

Note: Set up any optional trip information fields before continuing (see www.intempconnect.com/help for details).

App only users:

- In the app, tap the Settings icon and tap CX450 Logger.
- Tap the plus in the upper right corner.
- Type a profile name.
- Tap Logging Interval. Select a logging interval and tap Save.
- Tap Start and select the option for when you want logging to begin.
- Set up alarms if desired.
- Tap Save to add the new profile.

5. Configure the logger.

- Tap the Devices icon in the app. Find the logger in the list and tap it to connect to it.
- Once connected, tap Configure. Swipe left and right to select a logger profile. Type a name or label for the logger. Tap Start to load the selected profile to the logger. **InTempConnect users:** If the profile does not yet appear in the app, close and then reopen it, and repeat steps a and b. In addition, if trip information fields were set up, you will be prompted to enter additional information. Tap Start in the upper right corner when done.

Note: You can also use the CX5000 Gateway to automatically configure loggers. See www.intempconnect.com/help for details.

If you are having trouble connecting:

- Make sure the logger is within range of your mobile device. The range for successful wireless communication is approximately 30.5 m (100 ft) with full line-of-sight.
- If your device can connect to the logger intermittently or loses its connection, move closer to the logger, within sight if possible.
- Change the orientation of your phone or tablet to ensure the antenna in your device is pointed toward the logger. Obstacles between the antenna in the device and the logger may result in intermittent connections.
- If the logger appears in the list, but you cannot connect to it, close the app, power down the mobile device, and then turn it back on. This forces the previous Bluetooth connection to close.

6. Deploy and start the logger. Place the logger in the location where you will be monitoring the temperature and humidity. Logging will begin based on the settings in the profile selected.

Once logging begins, press the Next button on the logger to switch between the latest temperature and humidity readings, as well as the minimum and maximum values for both (see *Minimum and Maximum Values* for more details). See *Downloading the Logger* for details on how to access the logged data.

Logger Alarms

You can set up an alarm to trip on the logger when a temperature and/or humidity reading falls above or below a specified value. Specific alarm settings are set in the logger profile that you create in either InTempConnect or in the app.

When an alarm trips:

- The logger LED will blink every 5 seconds.
- The alarm icon will appear on the LCD and in the app.
- If audible alarms are enabled in the logger profile, the logger will beep as follows every 15 seconds:
 - One quick beep for temperature alarms.
 - Two quick beeps for RH alarms.
 - One long beep if multiple alarms were tripped at the same time.
- An Alarm Tripped event is logged.

To mute a beeping alarm, press the Mute button on the logger. Once muted, you cannot turn the beeping back on.

Download the logger to view details about the tripped alarm and to clear alarm indicators in the app and on the LCD.

Minimum and Maximum Values

The logger LCD displays the minimum and maximum temperature and humidity readings for the entire logging period. These values reset automatically when the logger is downloaded and restarted or stopped and reconfigured.

You can also clear these values as needed while the logger is logging by pressing both buttons on the logger simultaneously for 3 seconds until HOLD disappears on the LCD. Dashes (--) will then appear on the LCD for the minimum and maximum values until the next logging interval. The values will then continue to be updated for the remaining logging period or until they are cleared again. **Note:** This clears the data on the screen only. Actual logger and reporting data will not be cleared with this reset.

Passkey Protection

The logger is protected by an encrypted passkey automatically generated by the InTemp app for InTempConnect users and optionally available for local users who are using the app only. The passkey uses a proprietary encryption algorithm that changes with every connection.

InTempConnect Users

Only InTempConnect users belonging to the same InTempConnect account can connect to a logger once it is configured. When an InTempConnect user first configures a

logger, it is locked with an encrypted passkey that is automatically generated by the InTemp app. After the logger is configured, only active users associated with that account will be able to connect to it. If a user belongs to a different account, that user will not be able to connect to the logger with the app, which will display an invalid passkey message. Administrators or users with the required privileges can also view the passkey from the device configuration page in InTempConnect and share them if needed. See www.intempconnect.com/help for more details.

Local Users

If you are not using InTempConnect and instead logging into the app as a local user, you can create an encrypted passkey for the logger that will be required if another phone or tablet attempts to connect to it. This is recommended to ensure that a deployed logger is not mistakenly stopped or purposely altered by others.

To set a passkey:

1. Tap the Devices icon and connect to the logger.
2. Tap Set Logger Passkey.
3. Type a passkey up to 10 characters.
4. Tap Save.
5. Tap Disconnect.

Only the phone or tablet used to set the passkey can then connect to the logger without entering a passkey; all other mobile devices will be required to enter the passkey. For example, if you set the passkey for the logger with your tablet and then try to connect to the device later with your phone, you will be required to enter the passkey on the phone but not with your tablet. Similarly, if others attempt to connect to the logger with different devices, then they would also be required to enter the passkey. To reset a passkey, simultaneously press both the top and bottom button on the logger for 10 seconds, or connect to the logger in the app, tap Set Logger Passkey, and select Reset to Factory Default.

Downloading the Logger

You can download the logger to a phone or tablet and generate reports that include temperature and humidity readings, events, user activity, alarm information, and more. Reports can be shared immediately upon download or accessed later in the app.

InTempConnect users: Privileges are required to download, preview, and share reports in the app. Report data is automatically uploaded to InTempConnect when you download the logger. Log into InTempConnect to build custom reports (requires privileges).

Note: InTempConnect users can also download CX loggers automatically on a regular basis using the CX5000 Gateway. See www.intempconnect.com/help for details.

To download the logger:

1. Tap the Devices icon and connect to the logger.
2. Tap Download.
3. Choose a download option:
 - Download & Continue. The logger will continue logging once the download is complete.

- **Download & Restart.** The logger will start a new data set using the same profile once the download is complete.
- **Download & Stop.** The logger will stop logging once the download is complete.

A report of the download is generated and is also uploaded to InTempConnect if you are logged into the app with your InTempConnect user credentials.

In the app, tap Settings to change the default report type and report sharing options. The report is also available in Secure PDF and XLSX formats for sharing at a later time. Tap the Reports icon to access previously downloaded reports. See www.intempconnect.com/help for details on working with reports in both the app and InTempConnect.

Logger Events

The logger records the following events to track logger operation and status. These events are listed in reports downloaded from the logger.

Event Name	Definition
Started	The logger started logging.
Stopped	The logger stopped logging.
Connected	The logger connected to the app.
Downloaded	The logger was downloaded.
Alarm Tripped/Cleared	An alarm has tripped because the reading was outside the alarm limits or has cleared.
Safe Shutdown	The battery level dropped below 1.85 V; the logger performs a safe shutdown.

Deploying and Protecting the Logger

Use the four magnets on the back of the logger case to mount it to a magnetic surface.

The logger is designed for indoor use and can be permanently damaged by corrosion if it gets wet. Protect it from direct water contact. If the logger gets wet, remove the battery immediately and dry the circuit board.

Note: Static electricity may cause the logger to stop logging.

The logger has been tested to 8 KV, but avoid electrostatic discharge by grounding yourself to protect the logger. For more information, search for “static discharge” on onsetcomp.com.

Battery Information

The logger requires two user-replaceable AAA 1.5 V alkaline or optional lithium batteries for operation at the extreme ends of the logger operating range. Expected battery life varies based on the ambient temperature where the logger is deployed, the frequency of connecting to the phone or tablet and downloading reports, the duration of audible alarms, and battery performance. New batteries typically last 1 year with logging intervals 1 minute or greater. Deployments in extremely cold or hot temperatures or a logging interval faster than 1 minute can impact battery life. Estimates are not guaranteed due to uncertainties in initial battery conditions and operating environment.

Note: Make sure the batteries installed have flat negative terminals. There should be no indent in the bottom of the batteries. Batteries with indents in the negative terminals may become loose and prevent proper operation.

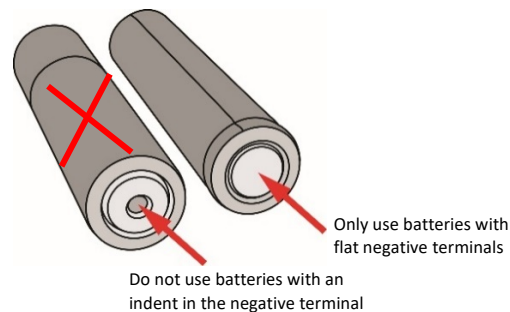

To install or replace the batteries:

1. If the battery door is already installed on the back of the logger, use a Phillips-head screwdriver to remove it.
2. Remove any old batteries.
3. Insert two new batteries observing polarity.
4. Screw the battery door into place.

⚠ WARNING: Do not cut open, incinerate, heat above 85°C (185°F), or recharge lithium batteries. The batteries may explode if the logger is exposed to extreme heat or conditions that could damage or destroy the battery case. Do not dispose of the logger or batteries in fire. Do not expose the contents of the batteries to water. Dispose of the batteries according to local regulations for lithium batteries.

Federal Communication Commission Interference Statement

This equipment has been tested and found to comply with the limits for a Class B digital device, pursuant to Part 15 of the FCC Rules. These limits are designed to provide reasonable protection against harmful interference in a residential installation. This equipment generates uses and can radiate radio frequency energy and, if not installed and used in accordance with the instructions, may cause harmful interference to radio communications. However, there is no guarantee that interference will not occur in a particular installation. If this equipment does cause harmful interference to radio or television reception, which can be determined by turning the equipment off and on, the user is encouraged to try to correct the interference by one of the following measures:

- Reorient or relocate the receiving antenna
- Increase the separation between the equipment and receiver
- Connect the equipment into an outlet on a circuit different from that to which the receiver is connected
- Consult the dealer or an experienced radio/TV technician for help

This device complies with Part 15 of the FCC Rules. Operation is subject to the following two conditions: (1) This device may not cause harmful interference, and (2) this device must accept any interference received, including interference that may cause undesired operation.

FCC Caution: Any changes or modifications not expressly approved by the party responsible for compliance could void the user's authority to operate this equipment.

Industry Canada Statements

This device complies with Industry Canada license-exempt RSS standard(s). Operation is subject to the following two conditions: (1) this device may not cause interference, and (2) this device must accept any interference, including interference that may cause undesired operation of the device.

Avis de conformité pour l'Industrie Canada

Le présent appareil est conforme aux CNR d'Industrie Canada applicables aux appareils radio exempts de licence. L'exploitation est autorisée aux deux conditions suivantes : (1) l'appareil ne doit pas produire de brouillage, et (2) l'appareil doit accepter tout brouillage radioélectrique subi, même si le brouillage est susceptible d'en compromettre le fonctionnement.

To comply with FCC and Industry Canada RF radiation exposure limits for general population, the logger must be installed to provide a separation distance of at least 20cm from all persons and must not be co-located or operating in conjunction with any other antenna or transmitter.

Pour se conformer aux limites d'exposition aux rayonnements RF de la FCC et d'Industrie Canada pour la population générale, l'enregistreur doit être installé de manière à fournir une distance de séparation d'au moins 20 cm de toutes les personnes et ne doit pas être colocalisé ou fonctionner avec une autre antenne ou un autre émetteur.